

INOX | Dual temperature drawers

DUAL TEMPERATURE ▶ GN1/1 ▶ REFRIGERATED DRAWERS

DWT 90

DETAILS



GENERAL FEATURES

- Single drawer switchable cooling/freezer (N.2 GN1/1 Pans)
- Dual temperature model (Easily switchable between cooler and freezer)
- Stainless Steel exterior and interior
- Ventilated Cooling
- Automatic defrost with electric heater
- Evaporator with anti-corrosion treatment
- Foaming Agent Cyclopentane (45mm per side)
- Digital Thermostat
- Sliding engine room for a manageable after sales servicing
- Easy removable condenser filter
- Front panel tilted holes for better air circulation
- Sliding drawers GN1/1 suitable for pans 150mm depth
- Removable Gasket
- N.4 Castor (N.2 in the front with brake)
- Energy efficiency class: -

TECHNICAL SPECIFICATIONS

Capacity	78 L
Temperature	-2°--8°C/-21°--18°C
Consumption	2.2/6.5 kWh/24h
Rated Power	345 W
Noise level	42 dB(A)
Net Weight	75 Kg
Gross Weight	85 Kg
External Dimensions (WxDxH mm)	905x700x605
Internal Dimensions (WxDxH mm)	626x520x150
Packaging dimensions (WxDxH mm)	945x740x680
Loading quantities 20'/40'/40'HQ	54/111/111

PRODUCT DIMENSIONS

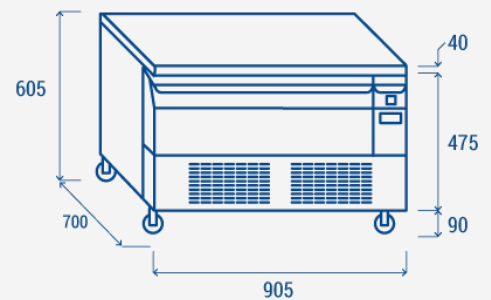

CERTIFICATION

CE RoHS

